



FCOWT

Fibre Optic Virtual Wide Band LNB + Terrestrial feeds

-  **RF adjuster for each output**
-  **Optical link monitor**
-  **Supplied with power supply**

Optical compact converter for terrestrial and vertical and horizontal wide band IF signals over a sole single-mode fibre optic. It can be used combined with Wide Band Multiswitch or directly to Sky Q wide band inputs. Also available the Satellite Wide Band output only.

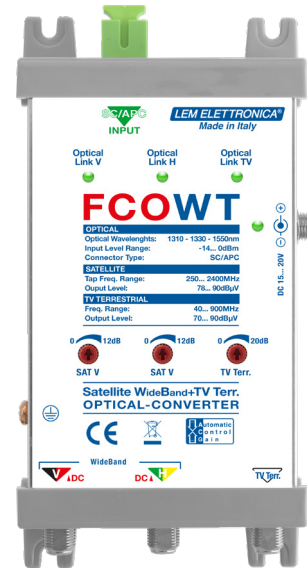

Ready for
UHDTV

WARRANTY **5** YEARS

MODEL		FCOWT
OPTICAL INPUT		1
RF OUTPUTS		3
OPTICAL		
OPERATION WAVELENGTH	nm	1310 - 1330 - 1550
INPUT POWER RANGE	dBm	-14... 0
INPUT CONNECTOR TYPE		SC/APC
RETURN LOSS	dB	≥40
SATELLITE		
OUTPUT BANDWIDTH	MHz	250... 2400
OUTPUT LEVEL	dBμV	78... 90
TV TERRESTRIAL / FM / DAB		
OUTPUT BANDWIDTH	MHz	40... 862
LEVEL ADJUSTER ATTENUATOR	dB	0... -20
OUTPUT LEVEL	dBμV	70... 90
OTHERS		
ISOLATION V / H	dB	> 30
OUTPUT RETURN LOSS	dB	> 12
DC INPUT VOLTAGE RANGE	V	12... 20
MAXIMUM CONSUMPTION	W	3,2
OPERATING TEMPERATURE	°C	0... 50
DIMENSIONS	mm	80x159x35

Connection Diagram

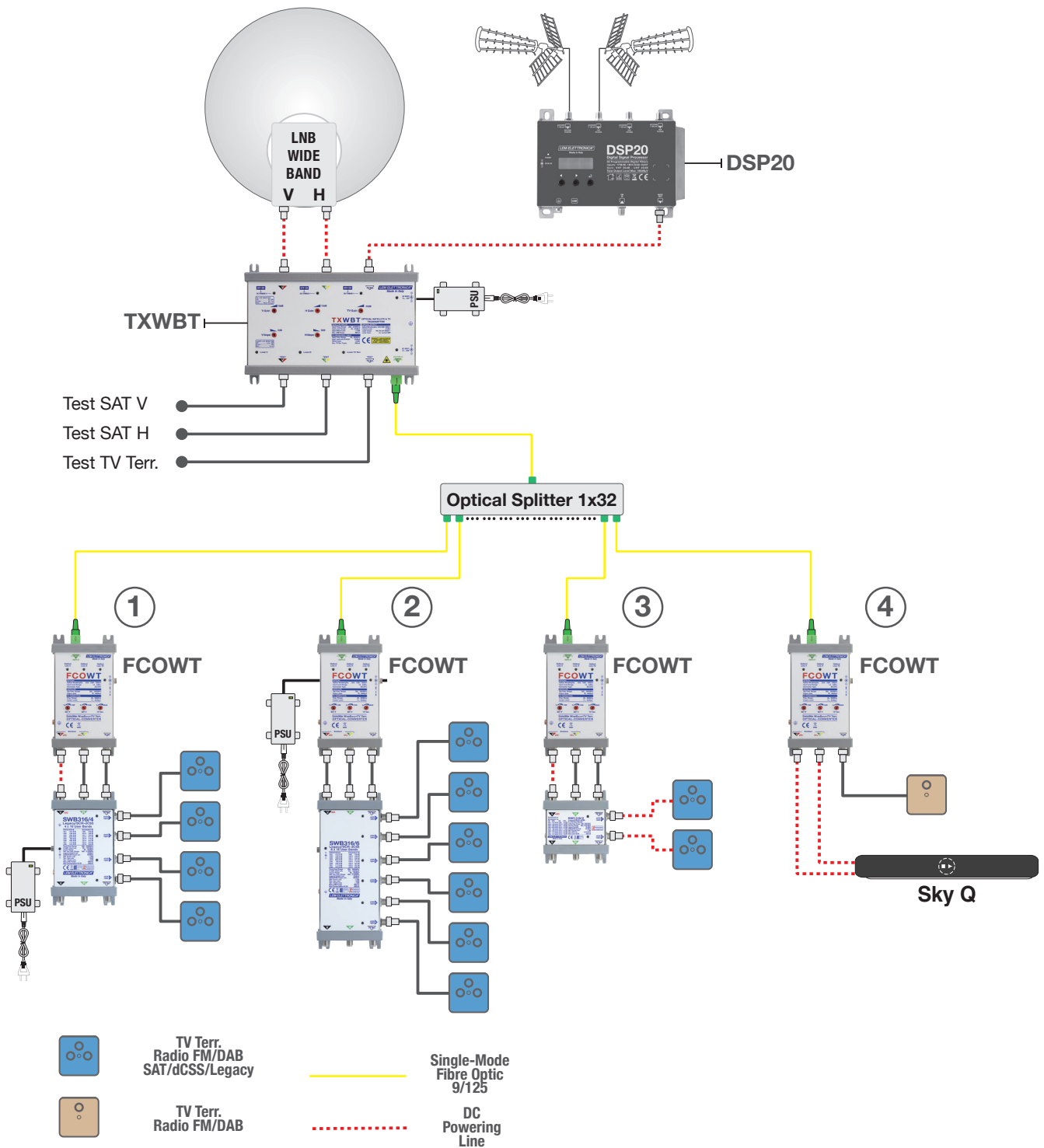

The **TXWBT** headend converts and transmits over a single-mode optical fibre cable the terrestrial signals (DTT, FM, DAB) and all the transponders of a satellite received from an Wide Band LNB. The conversion of the optical signals are performed by **FCOWT**. In the sample there are four suggested use and powering mode of the **FCOWT**:

- (1) Combined with a **SWB316/4** powered by the PSU connected to the multiswitch.
- (2) Combined with a **SWB316/8**, powering is provided by PSU connected to **FCOWT**
- (3) Combined with a **SWC316/2**, powering is provided by the Set-Top-Box.
- (4) Directly powered and connected to the Sky Q Wide Band inputs