

TXWDM

Optical Transmitter User manual

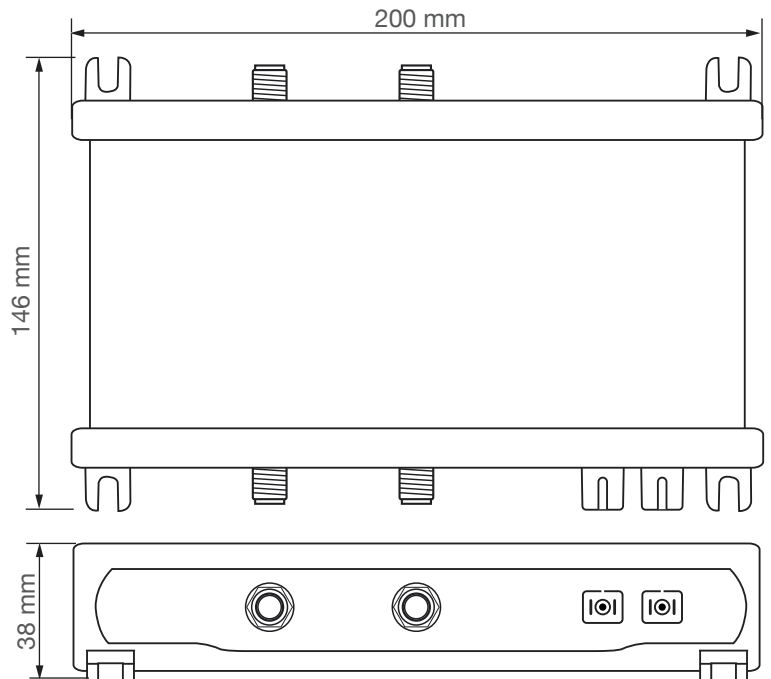







- V & H inputs for wide band LNB
- Built-in low loss CWDM
- Standard Wide Band LNB used
- Test and Monitor for each input
- Adjustable gain and slope for Satellite inputs
- Optical monitor Led for each Laser
- Double DC input for redundant power supply



Ready for **UHDTV** **MADE IN ITALY**

Rel. 1.0

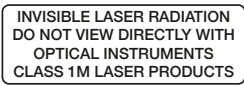
OPTICAL TRANSMITTER		TXWDM
RF INPUTS	n°	2
RF TEST OUTPUTS	n°	2
OPTICAL OUTPUT	n°	1
OPTICAL LOOP THROUGH (for TXWBT or TXWB)	n°	1
OPTICAL		
OUTPUT WAVELENGTH	nm	1.270 - 1.490
LASER TYPE		UN-COOLED MULTI QUANTUM DFB
LASER CLASS		1M, EN 60825-1
OUTPUT POWER	dBm	≥7
INPUT WAVELENGTHS LOOP THROUGH	nm	1310 - 1330 - 1550
INPUT CONNECTOR		SC/APC
OUTPUT CONNECTOR		SC/APC
SATELLITE		
INPUTS BANDWIDTH (for Wide Band LNB)	MHz	250... 2.400
INPUT RANGE LEVEL (ADJUSTABLE)	dBμV	70... 90
A.C.G. RANGE	dB	20
SLOPE ADJUSTER RANGE	dB	0... 9
RETURN LOSS	dB	>12
LNB REMOTE FEEDING		5,25W (15VDC/350mA)
OTHERS		
DC INPUT VOLTAGE	V	12... 20
MAX. POWER CONSUMPTION WITHOUT EXTERNAL LOAD	W	3
MAX. POWER CONSUMPTION WITH EXTERNAL LOAD	W	9
SHORT-CIRCUIT PROTECTION		ALL INPUTS
DIMENSIONS	mm	146x200x38
OPERATING TEMPERATURE	°C	0... +50

DESCRIPTION OF SYMBOLS AND ELECTRICAL SAFETY	
	The equipment complies with the CE requirements
	The equipment is designed for indoor use only
	Equipment grounding terminal
	This symbol indicates that the equipment complies with the class II equipment safety requirements
	To avoid the risk of electric shock, do not open the equipment.
	Invisible Laser Radiation avoid direct exposure to beam
	Class 1M laser product. Do not watch directly with optical instruments
	The equipment is compliant with RoHS 2011/65EU
	Dispose according to local authorities recycling processes

Safety instructions

1. Read carefully these instructions
2. Keep these instructions
3. Heed all warnings
4. Follow all instructions
5. Do not expose this apparatus to extreme temperatures
6. Do not install this apparatus near water or expose to rain and moisture
7. Place the apparatus in a dry and well-aired location
8. Install the unit on a vertical wall, or in a waterproof cabinet with a minimum IP55 rating, and fix it safely using the provided fixing plugs
9. Do not install the unit lying flat or on its top
10. Connect the power adapter cord to a detachable power supply socket
11. Unplug the apparatus during lightning storms or when unused for long time
12. Only use accessories specified by the manufacturer
13. Do not remove the cover without disconnecting from the mains first
14. Ambient temperature should not be lower than 0°C and higher than 50°C
15. Please allow air circulation around the apparatus



Installation warnings



INVISIBLE LASER RADIATION
DO NOT VIEW DIRECTLY WITH
OPTICAL INSTRUMENTS
CLASS 1M LASER PRODUCTS

Place the apparatus and the power supplier in a dry and well-aired location

Install the unit on a vertical wall, or in a waterproof cabinet with a minimum IP55 rating, and fix it safely using the provided fixing plugs

Use only the power supplier YS25-1501250 provided with the amplifier.

The use of not-original power suppliers determines the not-compliance of the product and can cause malfunctions and void the warranty

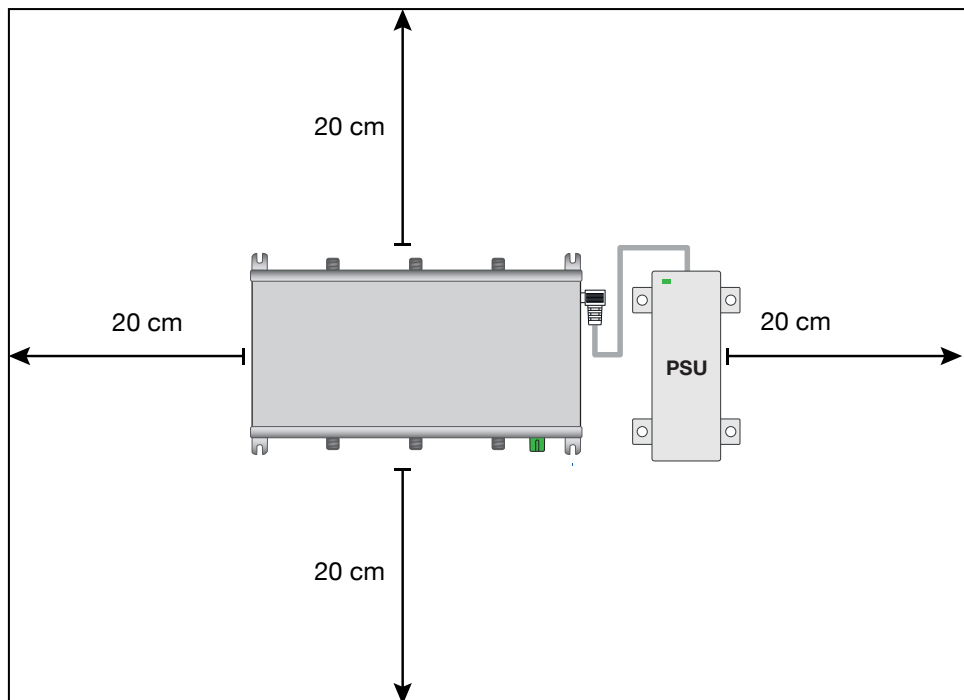

TXWDM DESCRIPTION

Box Content

01 TXWDM Optical transmitter

01 Power supplier YS25-1501250 (Input: 100-240Vac 0,5A Max / Output: 15Vdc 1,25A Max)

08 6x30mm fixing plugs with 4,5x40mm screws

01 User manual

- ① Wide Band LNB V - H inputs
- ② DC Input and power Leds
- ③ SC/APC Optical Output
- ④ SC/APC Optical Input
- ⑤ Satellite V-H Test/Monitor
- ⑥ Laser ON/OFF switches
- ⑦ Laser status Leds
- ⑧ H-V Level adjusters
- ⑨ Satellite V-H slope adjusters
- ⑩ Remote power feeding switches and Leds

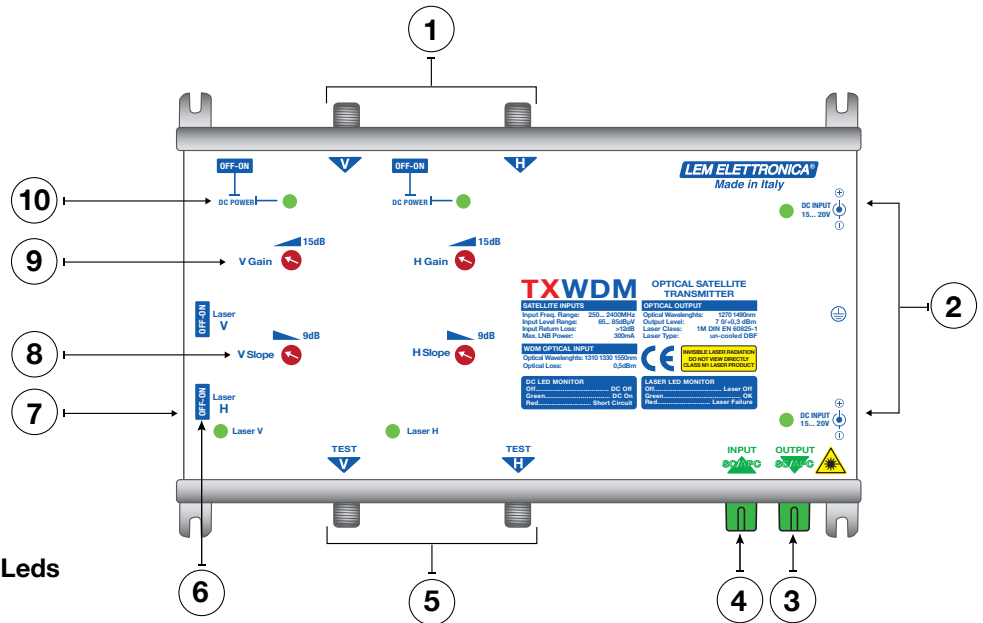

LED MONITOR DESCRIPTION

DC Input Led

Off= No power at the DC input

Green= DC Power

Laser Led

Off= Laser inactive

Green= Laser active

Red= Laser malfunction

Remote power Led

Off= No power

Green= Remote power feeding active

Red= Short circuit

Satellite V e H Wide Band inputs adjustments.

Because of possible different levels of propagation due to weather conditions the **TXWDM** Wide Band inputs are equipped with automatic Gain Control circuits. For perfect signal loss compensation and negative slope equalization of the coaxial cable between the LNB WideBand and the transmitter inputs no additional devices are required. The **TXWDM** Satellite V and H inputs have built-in pre-amplifiers and tilt adjusters.

For optimal working range of the A.C.G. circuits please set-up the slope and signal level of each input first.

Tilt adjuster

- 1_Activate at least one V or H for LNB power feeding.
- 2_Connect a Satellite Signal Meter in spectrum mode to the **TEST V** port (Vertical polarization) of the **TXWDM** transmitter. Rotate the **VSlope** adjuster until the spectrum appears flat.

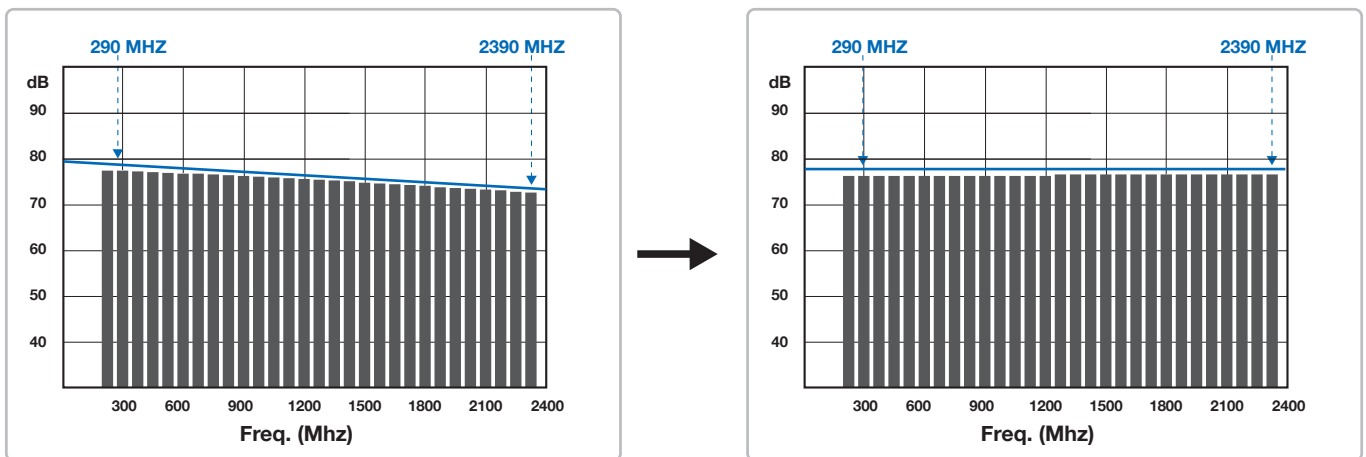

Input pre-amplifier gain adjustment

- 1_Select with the Satellite Signal Meter a transponder and operate on the **VGain** adjuster to obtain a level comprised between 70 and 75 dB μ V.

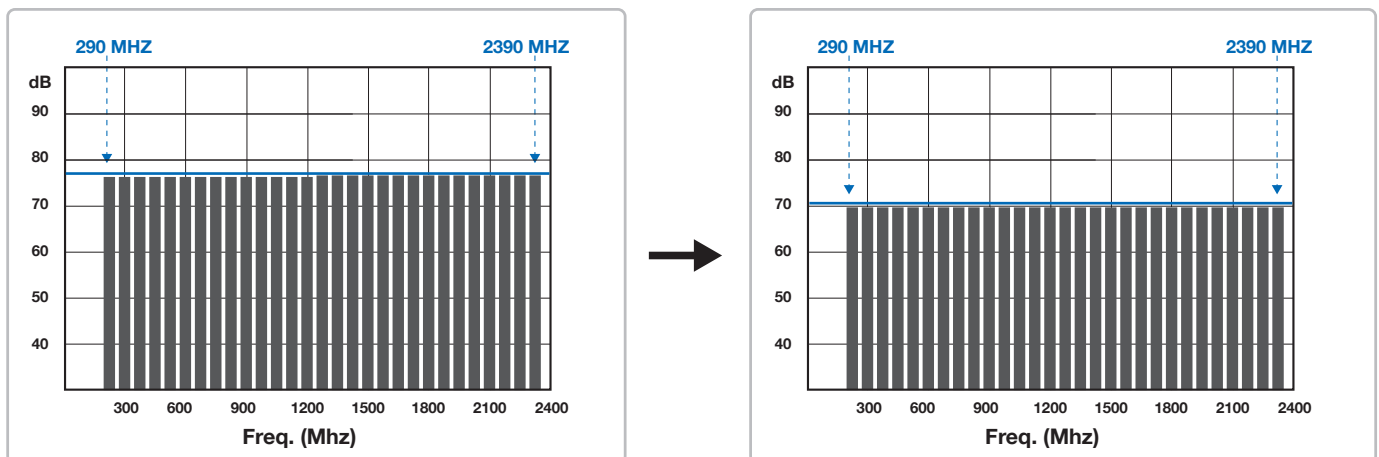

To set-up the H horizontal Wide Band input connect the Satellite Signal Meter to H Test port and repeat step by step the same procedure applied for the input.

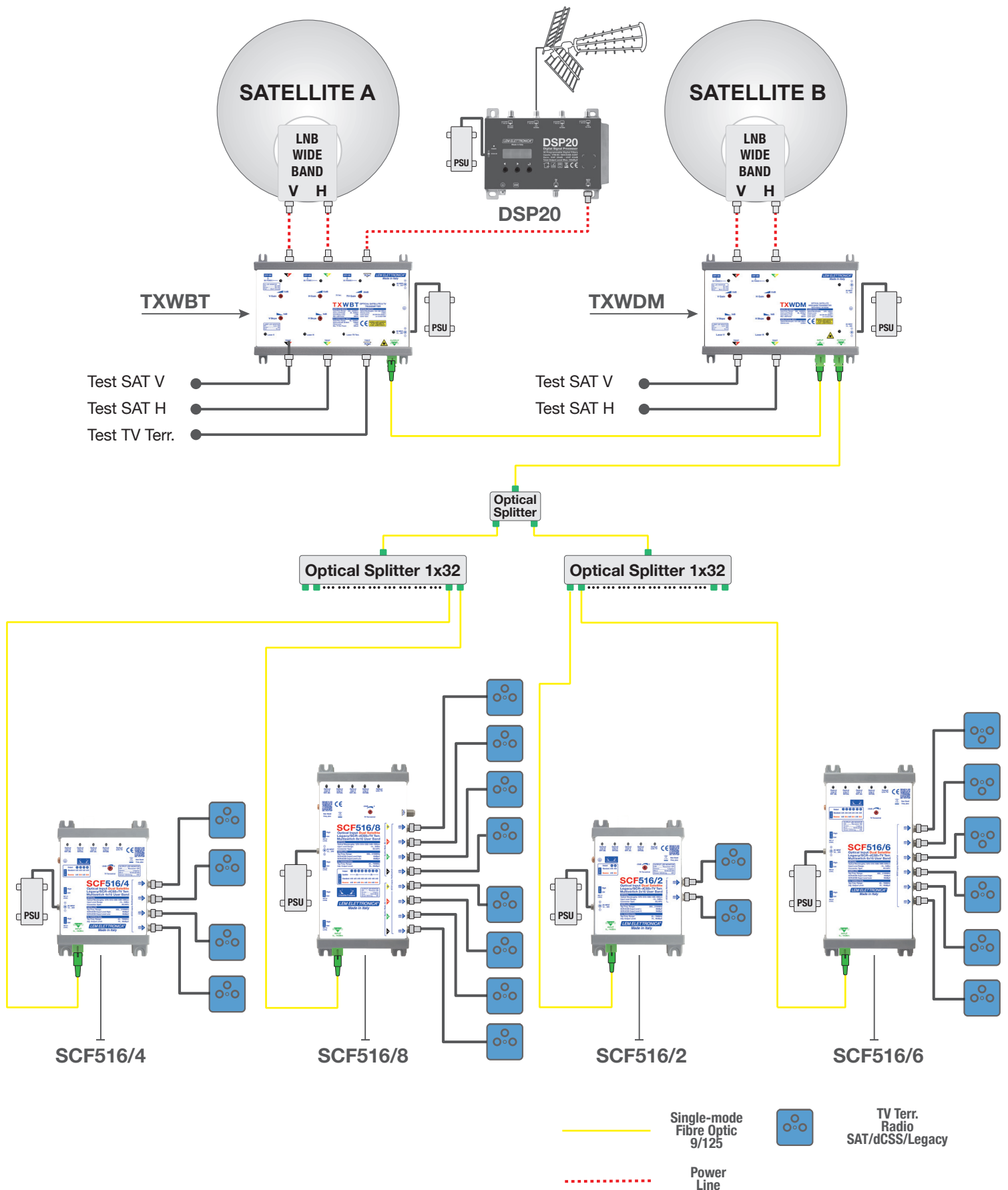

Distribution of two satellite and terrestrial feed (DTT, FM, DAB) over a single-mode optical fibre

The headends **TXWBT** and **TXWDM** convert and transmit over a single-mode fibre optical cable the terrestrial feeds and all the transponders of two satellite received from two Wide Band LNB. The optical multiswitches of the SCF516 series receive and converted into RF to be ready for a single or multi-dwelling coaxial distribution. Each SCF516 series multiswitch output provides terrestrial and satellite signals and fully supports Dseqc controls in legacy and SCR/dCSS standards.

Label with serial and tracking data

AA1000015019-X1020L

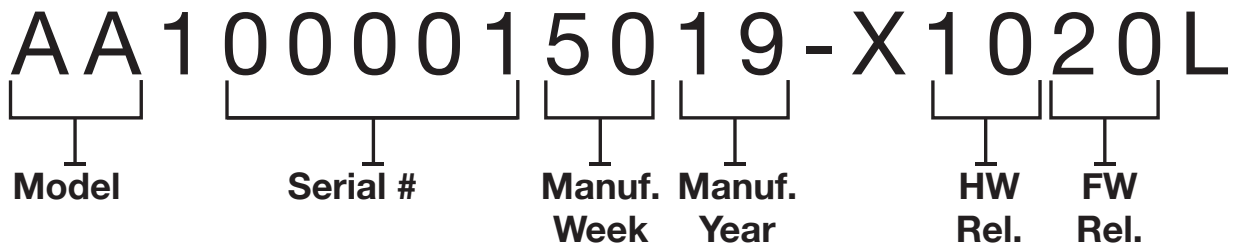

Model Serial # Manuf. Week Manuf. Year HW Rel. FW Rel.